

**IS : 5525 - 1969**  
( Reaffirmed 1990 )

# *Indian Standard*

## RECOMMENDATIONS FOR DETAILING OF REINFORCEMENT IN REINFORCED CONCRETE WORKS

( Seventh Reprint FEBRUARY 1996 )

UDC 721.021:744.4:693.554

© *Copyright* 1970

**BUREAU OF INDIAN STANDARDS**  
MANAK BHAVAN, 9 BAHADUR SHAH ZAFAR MARG  
NEW DELHI 110002

# Indian Standard

## RECOMMENDATIONS FOR DETAILING OF REINFORCEMENT IN REINFORCED CONCRETE WORKS

Joint Sectional Committee for Concrete Reinforcement, BSMDC 8

### Chairman

SHRI C. P. MALIK

### Representing

Central Public Works Department.

### Members

SHRI B. D. AHUJA

National Buildings Organization

SHRI O. N. GUPTA ( *Alternate* )

SHRI A. P. BAGCHI

Sahu Cement Service, New Delhi

SHRI K. K. BASU

Indian Iron & Steel Co Ltd, Calcutta

SHRI B. B. BHATTACHARJEE

IRC Steels Ltd, Calcutta

SHRI A. S. BISHNOI

Ministry of Transport & Shipping ( Roads Wing )

SHRI H. P. BODHANWALLA

Tata Iron & Steel Co Ltd, Jamshedpur

DR S. M. K. CHETTY

Central Building Research Institute ( CSIR ),  
Roorkee

DEPUTY DIRECTOR STANDARDS  
( B & S )-1

Research Designs & Standards Organization  
( Ministry of Railways )

ASSISTANT DIRECTOR STANDARDS  
( M/C ) ( *Alternate* )

DIRECTOR ( FARAKKA BARRAGE )

Central Water & Power Commission

SHRI V. GULATI

Heatly & Gresham Ltd, New Delhi

SHRI B. N. GUPTA

Steel Re-Rolling Mills Association of India, Calcutta

SHRI S. BANERJEE ( *Alternate* )

SHRI P. K. GUPTA

National Metallurgical Laboratory ( CSIR ),  
Jamshedpur

SHRI HARCHAND SINGH

Indian Steel and Wire Products Ltd, Jamshedpur

SHRI R. R. KAPLISH ( *Alternate* )

SHRI C. L. N. IYENGAR

The Concrete Association of India, Bombay

SHRI Y. K. MEHTA ( *Alternate* )

SHRI S. S. KASHYAP

Gammon India Limited, Bombay

SHRI S. Y. KHAN

Killick Nixon & Co Ltd, Bombay

SHRI S. M. BILGRAMI ( *Alternate* )

SHRI S. C. MAZUMDAR

Gannon Dunkerley & Co Ltd, New Delhi

SHRI N. H. PAI ( *Alternate* )

DR P. K. MOHANTY

Tor Isteg Steel Corporation, Calcutta

DR ING P. K. BANERJEE ( *Alternate* )

SHRI P. R. NAIR

Iron & Steel Controller, Calcutta

SHRI K. R. N. SWAMI ( *Alternate* )

SHRI M. L. NANDA

Central Public Works Department

SUPERINTENDING SURVEYOR OF

WORKS ( NORTHERN ZONE ) ( *Alternate* )

( Continued on page 2 )

( Continued from page 1 )

*Members*

BRIG O. P. NARULA  
SHRI B. K. PANTHAKY  
SHRI P. G. V. RAO  
PROF G. S. RAMASWAMY

SHRI Z. GEORGE ( *Alternate* )

REPRESENTATIVE

SHRI RUP RAI

SHRI R. G. JOG ( *Alternate* )

SECRETARY

SHRI SHIRISH H. SHAH

SHRI DINESH P. MEHD ( *Alternate* )

SHRI V. M. TALATI

SHRI R. NAGARAJAN,

Director ( Civ Engg )

*Representing*

Engineer-in-Chief's Branch, Army Headquarters  
Hindustan Construction Co Ltd, Bombay  
Directorate General of Supplies & Disposals  
Structural Engineering Research Centre ( CSIR ),  
Roorkee

M. N. Dastur & Co ( P ) Ltd, Bombay

Hindustan Steel Ltd, Ranchi

Central Board of Irrigation & Power, New Delhi

Tensile Steel Ltd, Bombay

Spun Pipe and Construction Co ( Baroda ) Ltd,  
Baroda

Director General, BIS ( *Ex-officio Member* )

*Secretary*

SHRI Y. R. TANEJA

Deputy Director ( Civ Engg ), BIS

**Panel for Detailing of Reinforcement, BSMDC 8 : P1**

*Convener*

BRIG O. P. NARULA

Engineer-in-Chief's Branch, Army Headquarters

*Members*

SHRI A. K. BHATTACHARYYA

Railway Board

DEPUTY DIRECTOR STANDARDS

Research Designs & Standards Organization

( B & S )

SHRI N. S. D. KHAMBHATI

Public Works Department, Government of Gujarat

SHRI M. S. JALUNDHWALA ( *Alternate* )

SHRI G. P. LAHIRI

Chatterjee & Polk, Calcutta

SHRI N. V. SHASTRI

Central Public Works Department

SHRI C. N. SRINIVASAN

M/s C. R. Narayana Rao, Madras

# *Indian Standard*

## RECOMMENDATIONS FOR DETAILING OF REINFORCEMENT IN REINFORCED CONCRETE WORKS

### 0. FOREWORD

**0.1** This Indian Standard was adopted by the Indian Standards Institution on 22 December 1969, after the draft finalized by the Joint Sectional Committee for Concrete Reinforcement had been approved by the Civil Engineering Division Council and the Structural and Metals Division Council.

**0.2** Much time, effort and expense can be saved in the design office and at the site of work, if simple, clear and comprehensive drawings are prepared. Different practices have hitherto been followed in various design offices in detailing of reinforcing steel in reinforced concrete structures and this has quite often resulted in waste of time and energy in interpretation of designers' ideas and instructions by various agencies connected with fabrication and placement of reinforcement and construction of reinforced concrete structures. It has been attempted in this standard to present unified and improved methods of preparing drawings for the fabrication and placing of reinforcing steel in reinforced concrete structures. The use of these improved methods, it is hoped, will not only result in better reinforced concrete construction but will also simplify and reduce the amount of work ordinarily required to prepare such drawings.

**0.3** These recommendations should be read in conjunction with IS : 456-1964\* and IS : 2502-1963†. While the common methods of detailing of reinforcement based on good practice have been recommended in this standard, suitable deviations may be made in special cases, if warranted by design requirements, provided they satisfy the requirements of IS : 456-1964\* and IS : 2502-1963† and ensure adequate safety by analysis or test or both.

**0.4** For the purpose of deciding whether a particular requirement of this standard is complied with, the final value, observed or calculated, expressing the result of a test or analysis, shall be rounded off in accordance with IS : 2-1960‡. The number of significant places retained in the rounded off value should be the same as that of the specified value in this standard.

\*Code of practice for plain and reinforced concrete ( *second revision* ).

†Code of practice for bending and fixing of bars for concrete reinforcement.

‡Rules for rounding off numerical values ( *revised* ).



## 1. SCOPE

1.1 This standard deals with the general requirements of detailing of reinforcement in reinforced concrete structures. The recommendations may be applied to all reinforced concrete structures with suitable modifications as may be necessary.

## 2. SYMBOLS AND ABBREVIATIONS

2.1 For the purpose of this standard and unless otherwise defined in the test, the symbols and abbreviations given in 2.1.1 to 2.1.4 may be used. All reinforcement bars used in the structures shall be suitably designated and numbered both in drawing and schedule.

### 2.1.1 Symbols Relating to Cross Sectional Shape and Size of Reinforcement Bars

	Plain round bar
	or
	Diameter of plain round bar
	Plain square bar
	or
	Side of plain square bar
	Deformed bar (including square twisted bar)
	or
	Nominal size (equivalent diameter or side) of the deformed bar (see Note)

NOTE — In accordance with IS: 1139-1966\* and IS: 1786-1966†, the nominal size of the deformed bar is equivalent to the diameter or side of a plain bar having the same weight per metre run as the deformed bar.



### 2.1.2 Symbols Relating to Shape of the Bar Along Its Length

<i>Bt</i>	Bent bar
<i>St</i>	Straight bar
<i>Stp</i>	Stirrup
<i>Sp</i>	Spiral
<i>Ct</i>	Column tie

\*Specification for hot rolled mild steel, medium tensile steel and high yield strength steel deformed bars for concrete reinforcement (revised).

†Specification for cold twisted steel bars for concrete reinforcement.

**2.1.3 Symbols Relating to Position and Direction**







<i>EW</i>	Each way
@	Spacing centre to centre
	Limit of area covered by bars
	Direction in which bars extend

**2.1.4 Symbols Relating to Various Structural Members**

<i>Bm</i>	Beam(s)
<i>Col</i>	Column(s)
<i>FG</i>	Footing(s)
<i>GR</i>	Girder(s)
<i>JT</i>	Joist(s)
<i>LL</i>	Lintel(s)
<i>LB</i>	Lintel Beam(s)
<i>Sb</i>	Slab(s)
<i>WL</i>	Longitudinal Wall
<i>WX</i>	Cross Wall

**2.2** The symbols, abbreviations and notes shall be used in a manner that will not create any ambiguity. For example, the notation  $5 \phi - 12$  both ways may be interpreted as 12 No. 5 mm dia bars in each direction making a total of 24 or 6 Nos. 5 mm dia bars in each direction making a total of 12. To avoid this, it is better to write  $5 \phi \text{ St}-12 \text{ EW}$ , that is, 12 No. 5 mm dia plain round straight bars in each direction. The same would be true in referring to each face of a concrete structure.

**2.3** The use of the same type of line for the same purpose considerably enhances the clarity and usefulness of the drawing. The following notations are suggested:

	Concrete line
	Unexposed concrete or masonry wall line
	Reinforcement
	Centre line
	Dimension line
	Concrete beam framing into column which extends through floor
	Concrete beam framing into column which stops at floor

**2.4** Where bars end up in hooks or bends, as far as possible the hooks and bends shall be clearly indicated in the drawing.

### **3. MARKS**

**3.1 Marks for Parts of Buildings** — Marks are used to designate the different structural members of a structure. Different structural members of a structure shall be marked using symbols, abbreviations and notations indicated in 2 and in the manner indicated in 3.2 and 3.3.

**3.2** A key framing plan shall be prepared to a convenient scale and the two axes marked, one side with alphabets A, B, C, etc, and the other with numbers ( see Fig. 1A ). Normally with rectangular pattern, the same key framing plan may be used for all floors. However, if arrangement of beams vary for different floors a separate key framing plan with grid arrangement and axes may be used for each of the floor. The floors shall be specified in accordance with requirements of IS: 2332-1963\* and abbreviations BT and MZ shall be used for basement and mezzanine respectively, for example:

BT — Basement  
MZ — Mezzanine  
Floor 1  
Floor 2

**3.2.1 Columns** — Columns and foundations shall be specified by grid arrangement giving reference to the floor, for example ( see Fig. 1A ):

FG E 1 — Footing for column E 1  
Col 2 E 1 — Column E 1 at floor 2 ( that is, column for storey 2,  
or column between floor 2 and 3 )

**3.2.2** Beams, slabs, and lintels, tie beams shall be consecutively numbered from left hand top corner ( see Fig. 1A ).

**3.2.3** If longitudinal section of the beam is shown, then the grid of the column or number of the beam supporting the beam that is being detailed shall be shown as indicated in Fig. 1B and if possible inset on the drawing showing the key framing plan; on the other hand if a beam schedule is included, a table ( see Fig. 1C ) may be prepared and inset on the drawing showing the key framing plan ( see Fig. 1A ).

**3.2.3.1** Beams or slabs that are similar may be given in the same number.

**3.3 Walls** — Marking of walls shall be made in the serial order starting from top left corner of plan and proceeding towards the right, followed by subsequent rows, in order. Longitudinal walls and cross walls shall be marked separately ( see Fig. 2 ) and identified in the drawing with reference to the serial number of the floor.

---

\*Nomenclature of floors and storeys ( Since revised ).

**Example:**

- 2 WL — 1 Longitudinal Wall No. 1 at floor 2 ( between floor 2 and 3 )  
 4 WX — 3 Cross Wall No. 3 at floor 4 ( between floor 4 and 5 )

**3.4** Floors and storeys shall be designated in accordance with requirements of IS : 2332-1963\*.

**4. SCALES**

**4.1** Scales shall be so chosen as to bring out the details clearly and to keep the drawings within workable size. The choice of scale will depend on the discretion of the designer and no general recommendations can be given in this respect, although commonly used scales are given below as examples:

Plan	—	1 : 100, 1 : 5
Elevation	—	1 : 5, 1 : 30
Sections	—	1 : 50, 1 : 30, 1 : 25, 1 : 15, 1 : 10

**5. STRUCTURAL DRAWINGS**

**5.1** Structural drawings prepared by the designer shall show details of reinforcement and all other information needed for detailing the reinforcement. The drawings shall also indicate by separate notes, live loads, concrete strength, quality and grade of steel, number of bars to be lapped and lengths of laps, concrete cover and if necessary, any special instructions regarding erection of form work, fabrication and placing of steel.

**5.2** It is always convenient to detail and fabricate the reinforcement by units which generally consist of footings, walls, columns, each floor and roof. A separate structural drawing supplemented by bar bending schedule should preferably be made for each unit. For small structures the entire requirements may be handled as one unit. For a large project a particular unit such as floor may be divided to correspond with the construction schedule. All sections should be kept as large as practicable, since it is more economical to fabricate for large units, especially where there is liable to be a duplication of bars. All the drawings in one set should preferably be of the same size.

**5.2.1** In bridge work, especially for typical designs that are often repeated it is customary to show the details of reinforcement bars on the general drawing

**5.3** To ensure that all of the reinforcement is properly placed or positioned in a unit, a longitudinal section or cross-section or both should be shown in addition to the plan and elevation of the unit on which the bars are shown.

\*Nomenclature of floors and storeys ( Since revised ),



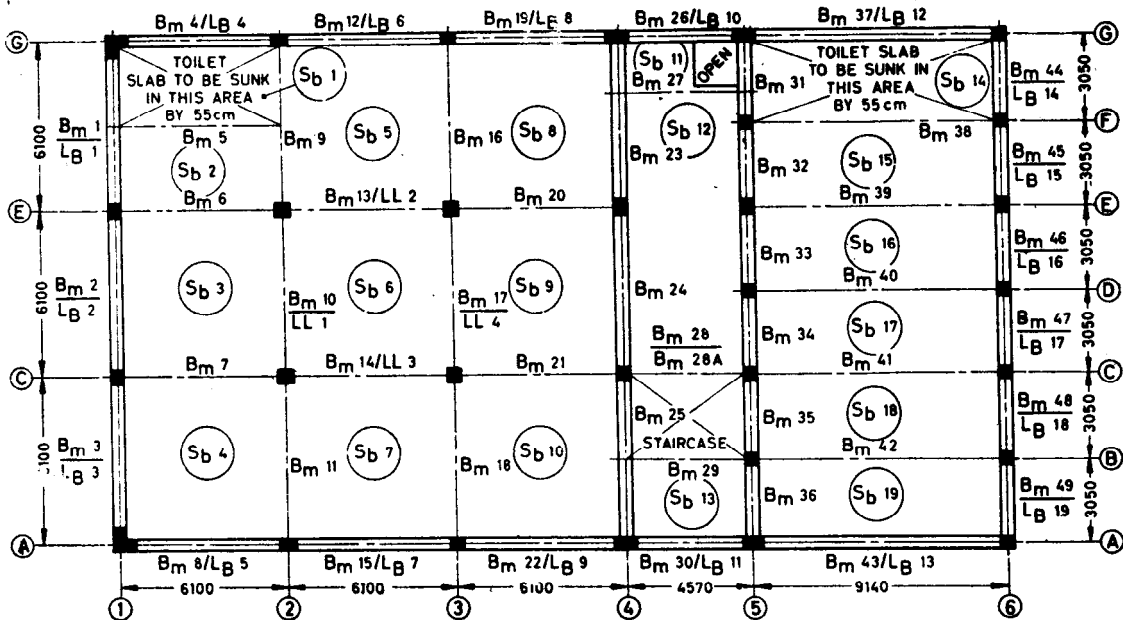

1A

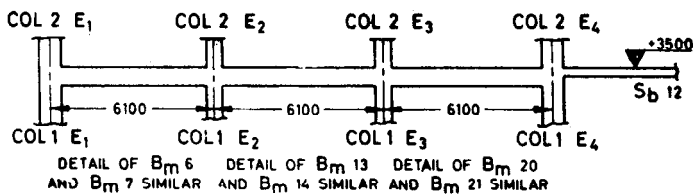

1B

Beam No.	Floor	Spanning Between	At Level mm
B <sub>m</sub> 1	1	E <sub>1</sub> G <sub>1</sub>	+3500
B <sub>m</sub> 14	1	C <sub>2</sub> C <sub>3</sub>	+3500
B <sub>m</sub> 27	1	B <sub>23</sub> B <sub>31</sub>	+3500
B <sub>m</sub> 28	1	C <sub>4</sub> C <sub>5</sub>	+3500
B <sub>m</sub> 28A (Landing Beam)	1	C <sub>4</sub> C <sub>5</sub>	+1750
B <sub>m</sub> 29	1	B <sub>5</sub> B <sub>25</sub>	+3500
LB 1	1	E <sub>1</sub> G <sub>1</sub>	+2440
LB 9	1	A <sub>3</sub> A <sub>4</sub>	+2440

1C

FIG. 1 TYPICAL ARRANGEMENT FOR THE KEY FRAMING PLAN AND MARKING DIFFERENT STRUCTURAL MEMBERS

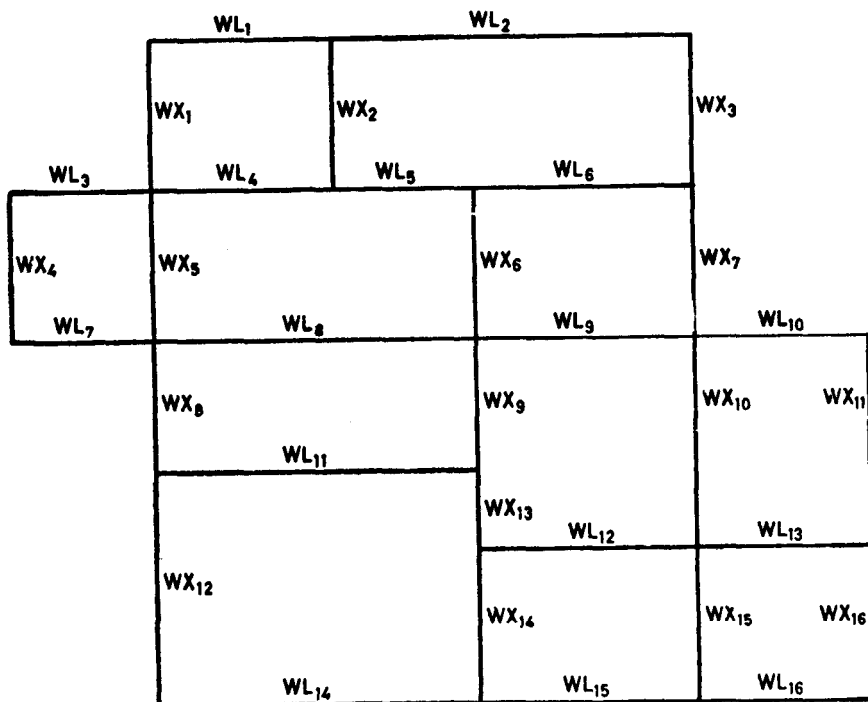

FIG. 2 TYPICAL MARKING DETAILS FOR WALLS

**5.4** The drawing should be complete and clear, so as to leave no doubt on any point of construction. Complete and accurate dimensions shall be shown. Clear and adequate details for special and unusual conditions shall be given to ensure proper placing of reinforcement. Details at corners and intersections of walls, bridge seat construction joints, window and door openings and similar special conditions should be shown in the relevant drawings along with sketches if necessary.

**5.5** For clear demarcation of reinforcement bars, those in the near face shall be shown in full lines and those that are placed in the far face shall be shown in dotted line.

**5.6** All bars, straight or bend, requiring hooks shall be so designated by the designer or a note to this effect included in the drawing.

**5.7** Lengths of laps, points of bend, and extension of bars should be specified by the designer. The ratios  $L/7$ ,  $L/5$  and  $L/4$ , etc shown on typical drawings shall not be used unless justified by structural analysis.

**5.8** Different sizes of bar supports such as holsters and high chairs in increments in which stock sizes are commonly available shall be indicated on the drawing.

**5.9** Wherever possible, all control and construction joints should be indicated on structural drawings and details provided for such joints.

**5.10 Notes and Instructions** — Any ambiguity and scope for misinterpretation of instructions shall be avoided. All instructions shall be in the imperative form, specific, brief and clear.

### **5.11 Schedules**

**5.11.1** The reinforcement of slabs, beams and many other parts of structures may be effectively shown on working drawings or in a tabular form, known as a schedule. The schedule is a compact summary of the dimensions of the concerned structural part, all the bars complete with the number of pieces, shape and size, lengths and bending details from which fabrication details may be easily worked out. Bar lengths for straight bars should preferably be detailed in increments of 75 mm.

**5.11.1.1** A schedule shall be supplemented with diagrams and sketches wherever necessary. Where bars of different dimensions are used, the exact arrangement of the reinforcement shall be shown by means of clear diagrams. No abbreviation or symbol shall be used in a schedule without proper explanation.

**5.11.1.2** For small structures detailed on a single sheet, the schedule may be placed in the upper left corner of the drawing. For larger structures requiring more than one drawing the complete schedule may appear on the last sheet of the details, or if the size of the structure warrants, separate schedules may be prepared for each unit ( foundation, abutments, piers, etc ) on the drawing covering that specific unit of the structure.

**5.11.2 Beams, Girders and Joists** — Details of reinforcement for beams, girders and joists are usually shown in schedules. The schedules should show the number, mark and size of number; number, size, position and length of straight bars; number, size, position, bending details and total length of bent bars and stirrups; size, shape and spacing of bar supports; and any other special information necessary for proper fabrication and placement of the reinforcement ( see Fig. 3 ). Care shall be taken not to omit any controlling dimension such as over-all length of the bar and height of the bent bar and location of bar with respect to supporting members where the bar is not placed symmetrically. The schedule should also include special notes on bending and any special information, such as the requirement of laps, two layers of steel.

**5.11.3 Slabs** — The reinforcement for slabs is generally indicated on the plan, with details for the various types of bend bars shown in a schedule ( see Fig. 3 and 4 ). The schedule shall be similar to that for bars in beams, except that the number of bars may also be obtained from the plan. Panels exactly alike shall be given an identifying mark or so specified in the schedule.



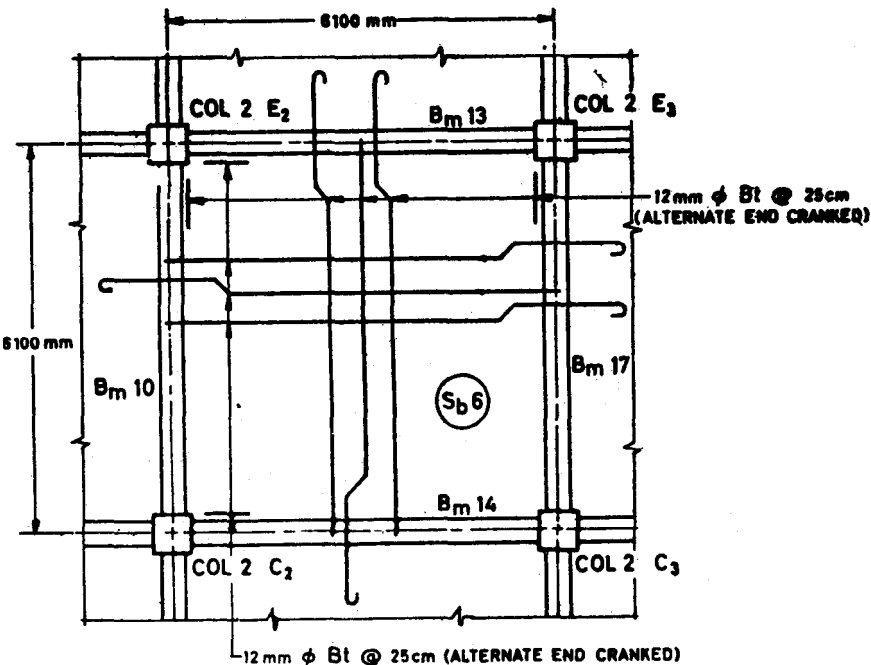
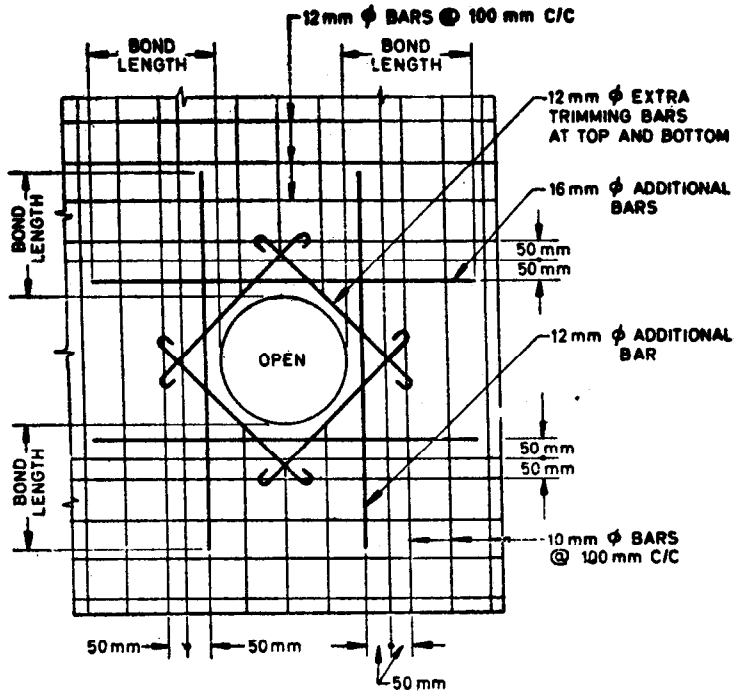

FIG. 4 TYPICAL DETAILS OF SLAB REINFORCEMENT IN STRUCTURAL DRAWING

**5.11.3.1** In skewed panels, bars shall be fanned to maintain given spacing in the mid span. Additional bars for reinforcing the openings shall be as shown on plan ( see Fig. 5 ).

**5.11.4 Walls** — The reinforcement for walls shall be indicated on the plan elevation and section with the details for various types of bent bars shown in schedule in a manner similar to that for beams and slabs.

**5.11.5 Columns** — The reinforcement for columns may be shown in a column schedule ( see Fig. 3 ). When pedestals are used, they should be included in the column schedule. Piles and pile caps should be treated as separate units and separate details or schedule or both may be provided. The main schedule may be supplemented with a smaller schedule for ties and bent bars, diagrams showing the arrangement and bending of the ties, and any special feature of the construction pertinent to the fabrication and placing of the column reinforcement ( see Fig. 6 and 7 ). In case of rectangular column the reinforcement details may be indicated with reference to framing plan. In case of square columns designed for building and axial load with unequal reinforcement in two directions, detailed plan should be given showing the reinforcement, the beams framing into the column, and other salient reference lines, so that the bars are placed in correct places in the plane of bending.



5A

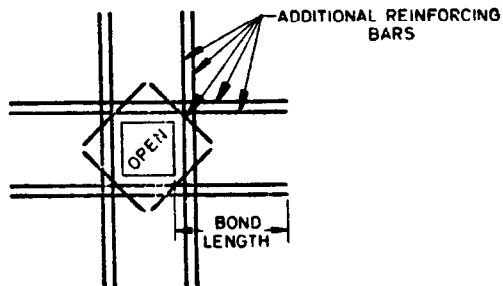

5B

NOTE — Cross-sectional area of the extra bars placed parallel to principal reinforcement should be at least equal to the area of principal reinforcement disturbed by the opening.

5 TYPICAL REINFORCEMENT DETAILS FOR OPENINGS IN SLAB

In addition to showing size and regular spacing of column ties, the designer shall also show any additional ties required for special conditions such as splices, offset-bends, etc ( see Fig. 6 ).

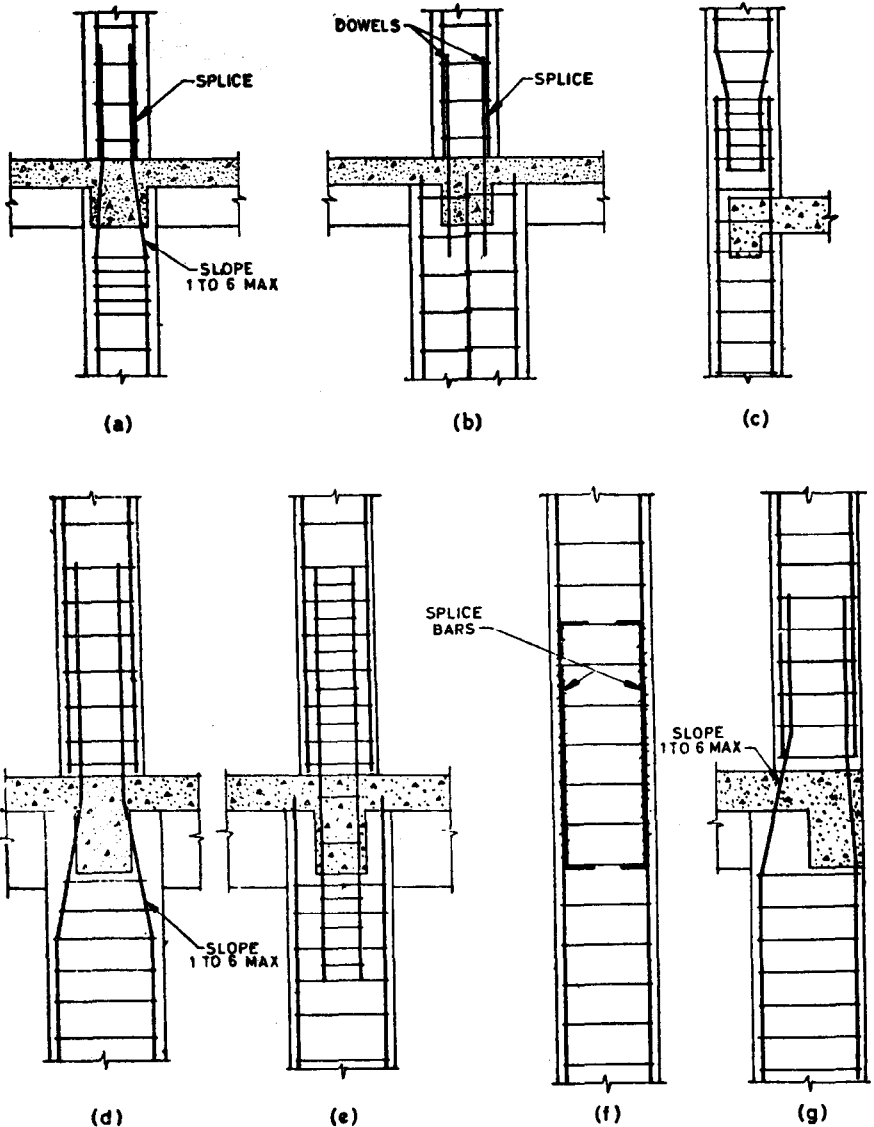

FIG. 6 TYPICAL DETAILS OF COLUMN SPLICES



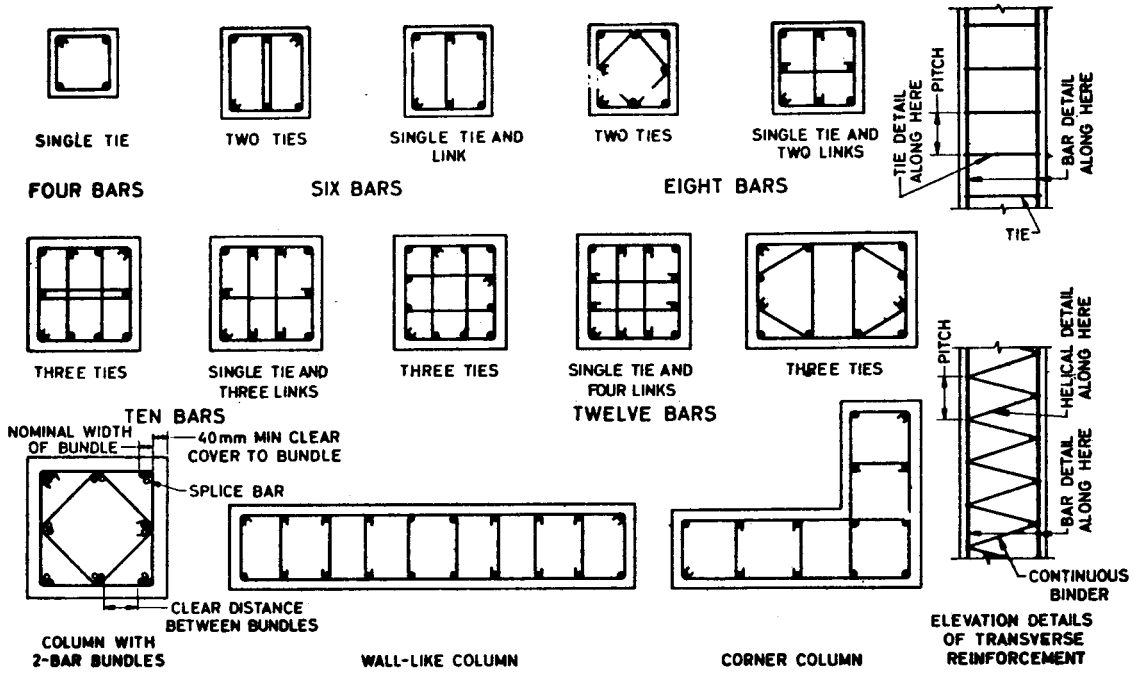

FIG. 7 TYPICAL ARRANGEMENT OF LATERAL TIES AND LINKS IN COLUMNS

**5.11.6 Dowels and Bar Supports** — Dowels and bar supports, spacer bars, bar chairs, etc, should be specifically listed on the structural drawing and should be scheduled in that portion of the structure in which they are first required so that they can be delivered with the reinforcement and are available for placement at proper time. Footing dowels shall be scheduled with footings rather than in column schedules.

**5.11.7 Other Structures** — On some types of structures, such as bridges, tanks, sewers and conduits, and certain components of buildings, such as stairs, special procedures may be used and adapted to the particular structure (see Fig. 8). The principal object is to show the reinforcement in a simple clear and easy manner. This may be accomplished by a small detailed sketch of each bar or type of bar with a table of dimensions.

## 6. MISCELLANEOUS

**6.1** Congestion of steel should be avoided at points where members intersect. It should be ensured that all reinforcement shown can be properly placed. For example, at the intersection of a beam and girder, the beam bars should be placed at a different elevation than those in the girder so as to avoid interference when the steel is being placed. Another very troublesome point is the intersection of columns with beams and girders and a large-scale layout detail should be shown on the drawing for guidance of steel setter (see Fig. 9).

**6.2** It should be ensured that hooked and bent bars can be placed in the form work and have adequate concrete cover.

**6.3** It should be ensured that the unusual bends shown in the drawing can be made with bending equipment normally available (see IS : 2502-1963\*).

**6.4** When a member has a break in its direction so that the reinforcement in tension tends to separate from the body of the concrete, special anchorage shall be provided and shown in detail. Examples are the junction of stairs and landings (see Fig. 8) the soffit of a beam forming an angle, inside corners of walls, and inside corners of rigid frames.

**6.4.1** Where slabs frame flush with the bottom of upstand beams, adequate reinforcement shall be provided to take care of extra tension.

**6.5** Where the lengths of bars are not specifically fixed, such as for temperature steel, slabs on ground and tie bars in floors culverts and retaining walls, stock lengths or lengths which can be cut from stock length with a minimum of waste should be used.

**6.6** When larger diameter bars are required in columns or in beams, and to avoid congestion they have to be welded rather than lapped for splicing, the method of welding should be specified as well as the location of the staggered welds at heights or positions convenient for welding.

\*Code of practice for bending and fixing of bars for concrete reinforcement.

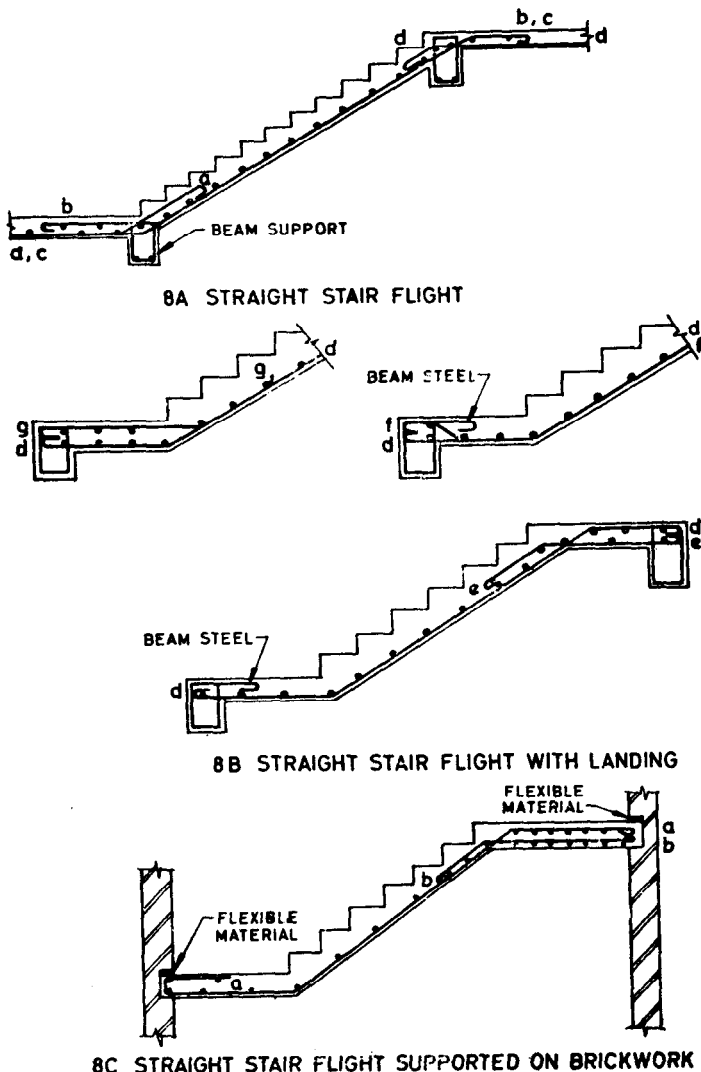

FIG. 8 TYPICAL DETAILS OF REINFORCEMENT IN STAIR FLIGHT

**6.7 Splices** — Where beams or girders require bars longer than carried in stock, the splices in the bars shall be made where the stress in the bar is minimum, that is, at the point of inflection. Splices in bent bars can sometimes be avoided by using straight top and bottom bars, though bent bars aid in carrying diagonal tension.

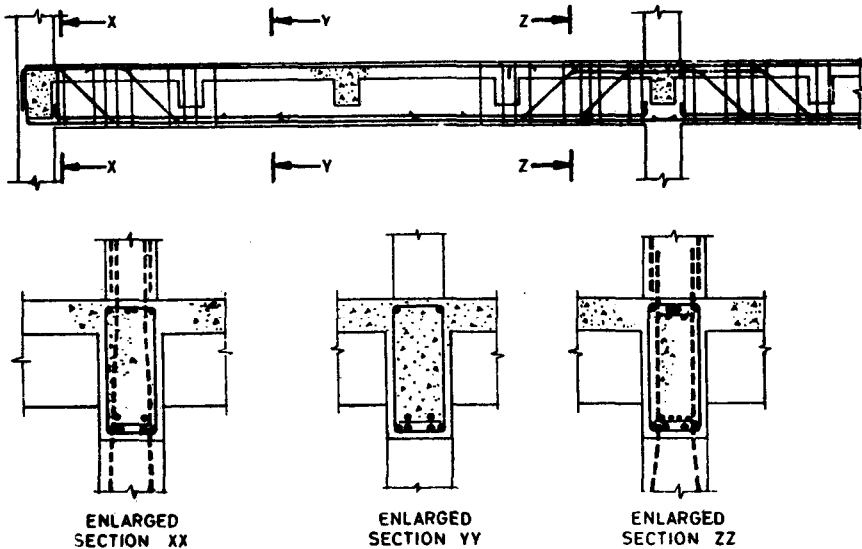

FIG. 9 TYPICAL REINFORCEMENT DETAILS AT JUNCTION OF COLUMN AND BEAM

Splices shall be staggered and shall be made by lapping, welding or other positive connections. Lap splices should, however, not be used for 45 mm and 50 mm deformed bars in tension. Splices shall be avoided where the critical design stress is tensile. Lapped bars, if used, may be either in contact or separated.

**6.7.1 Lap Splices** — Since the strength of a lap splice does not increase directly with the length of lap, but varies with bar diameter, concrete strength, position of the bar, distance from other bars, and type of stress ( compression or tension ), it is necessary for the designer to show length and location of all lap splices.

**6.7.1.1** At splice points, sufficient bars ( or dowels ) from the lower column shall extend into the upper column to provide not less than the sectional area of the bars in the upper column. These bars shall extend at least the minimum distance required for column splices. The remaining bars in the lower column shall extend to within 75 mm of the top of the floor, or to within 75 mm of the top of other member transmitting the additional load to the column.

**6.7.1.2** Where the tops of column bars are less than 1.8 m above the top of footings or pedestals, the bars shall extend into the footing or pedestal, and dowels shall not be used unless specifically indicated by the designer.

**6.7.1.3** Dowels shall have a cross-sectional area at least equal to that of the bars above and they shall extend both above and below the points

splice the minimum distance required for splices. The minimum length of lap shall be based on the size of the largest bar in the column above the splices.

**6.7.1.4** Where the depth of the footing, or footing and pedestal combined, is less than the minimum length of embedment required for dowels of the desired size, the size or number of dowels shall be increased and shown on design drawings. In exceptional cases, hooks at the bottom of the bars may be desirable to resist tension, but the length of bars in any such hook shall not be considered in determining the bond area provided for compression.

**6.7.1.5** The use of a tier of columns one above the other is rare in bridge construction, but when used, the practice described above should apply.

**6.7.2 Butt Splices** — Reinforcing bar butt splices may be made by arc welding, fusion welding, or using positive connection (mechanical connections). The properties of these connectors, and the reinforcing bar and preparation requirements vary with the type of connection used. It is important that the designer should specify the type of connection which will meet the design requirements (see IS : 456-1964\* and IS : 2751-1966†).

**6.7.2.1** Details of the more commonly used types of butt joint splices are shown in Fig. 10. On the drawings and on orders to the fabricating shop, the designer shall clearly show the reinforcing bar and preparation, the method of welding and details of positive connections, when used. In cases where material is ordered cut to length from the mill, consideration should be given while ordering length to allow for re-cutting by the fabricating shop.

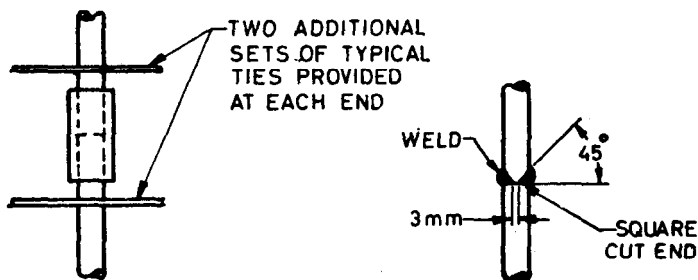

10A POSITIVE CONNECTION

10B WELDED SPLICE

FIG. 10 TYPICAL DETAILS OF BUTT SPLICES

**6.8 Dowels** — Dowels may be necessary for splicing column bars or where the concreting for part of the structure is delayed, or between various units

\*Code of practice for plain and reinforced concrete (second revision).

†Code of practice for welding of mild steel bars used for reinforced concrete construction.

of structures. Dowels should always be detailed first so that they will be delivered to the job at the proper time. Except for special cases in columns, dowels shall be of the same number, size, and grade as the bars joined and shall be of sufficient length to splice with the main bars.

**6.9 Longitudinal Reinforcement for Column** — Where a column at a particular floor is smaller ( in cross-section ) than the column immediately below it, the vertical bars from the lower column shall be offset to come within the upper column, or dowels shall be used. The slope of the inclined portion shall not exceed 1 in 6 ( see Fig. 6 ). In detailing offset column bars, a bar diameter should be added to the desired offset; and in the corners of square columns, the bars should be offset on the diagonal.

**6.9.1** Longitudinal reinforcement bars in squarer or rectangular columns should be offset bent into the column above. Longitudinal re-inforcing bars in round columns where columns size is not changed should be offset bent if maximum number of bars are desired in the column above. General practice is to sketch the offset for the corner bars which should be bent diagonally and make this the typical offset dimension for all the bars in the column.

**6.9.2** For any offset between column faces up to a maximum of 75 mm the longitudinal bars should be offset bent. When the offset exceeds 75 mm, the longitudinal bars in the column below should be terminated at the floor slab and separate dowels used.

**6.9.2.1** Where upstand beam is not provided, the height of the column equal to 75 mm above the floor level should be cast along with the lower column.

**6.9.3** When the bar arrangement changes between floors, bars may extend through, stop off, or require separate dowels. Each situation requires its own solution. Steel equal in area and bond capacity to that in the column above shall be extended.

**6.9.3.1** Column bars shall be spliced at the top of upstand beams rather than at floor level.

**6.9.4** Where column verticals are offset bent, additional ties shall be provided and placed not more than eight bar diameters from the point of bend. For practical purposes, three closely spaced ties are usually used, one of which may be part of the regularly spaced ties plus two extra ties. The designer should indicate the general arrangements of vertical bars and all tie requirements.

**6.9.5** Welded splices or other positive connections may be used as butt splices for vertical column bars instead of lapped splices. For bars of size 32 mm and above such splices or connections may be used to avoid overcrowding of the bars due to the extremely long laps which would otherwise be required. Special preparation of the ends of the vertical bars is usually

required. Where bars are arc welded, the most common practice is to provide a square-cut end at the top and a double bevelled end on the bottom of the upper bar to rest on the square-cut end. This permits filling the resulting space with weld metal to develop the splice ( see Fig. 10 ). Where a welded sleeve or mechanical device is used both ends of the bar may be either square cut or standard-shear cut, depending on the type of connection used. Since the points of splice are usually staggered between alternate vertical bars and the splice location will depend upon the design requirements, the designer should indicate the types of splices permissible and their location ( see IS : 456-1964\* and IS : 2751-1966† ).

**6.10 Lateral Reinforcement for Columns** — The arrangement of lateral ties and spirals shall conform to the requirements of IS : 456-1964\* and shall be adequately illustrated and detailed. Typical arrangement of ties for various numbers of longitudinal bars are shown in Fig. 7. If access to the interior of a column or pier is necessary some pattern of ties may be substituted provided the tie arrangement conforms to the requirements of IS : 456-1964\*. The arrangement should preferably be such as to leave the inside core area of the column free from maze of intersecting ties.

**6.10.1 Bundled bars** shall be tied, wired, or otherwise fastened to ensure, that they remain in position. End-bearing compression splices will be held concentric, all bundles of column verticals will be held by additional ties at each side of end-bearing splices, and any short splice bars added for tension should be tied as part of the bundle within the limit of four bars to a bundle. A corner of a tie should be provided at each bundle.

### **6.11 Spiral Reinforcement**

**6.11.1 General** — Spirals, whether in building or in bridges shall be provided with one and one-half extra turns at both top and bottom. Where necessary to splice the spiral it shall be done by shop welding or by a lap of one and one-half turns. Where a spiral cannot be furnished in one piece it may be furnished in two or more sections by providing one and one-half turns at each of the ends of each section to be lapped in the field. The sections shall be properly identified by mark numbers to ensure proper assembly.

**6.11.1.1** The height ( or length ) of a spiral is defined as the distance out-to-out of coils including the finishing turns at top and bottom with a tolerance of  $\pm 40$  mm. The maximum length of spacers shall be that of the spiral plus one pitch.

**6.11.2 Columns** — Unless otherwise specially provided, spirals shall be detailed as extending from the floor level or top of footing or pedestal to the

\*Code of practice for plain and reinforced concrete ( second revision ).

†Code of practice for welding of mild steel bars used for reinforced concrete construction.

level of the lowest horizontal reinforcement in the slab, drop panel, or beam above. In a column with a capital, it shall extend to the plane at which the diameter or width of the capital is twice that of the column. If the design requires lateral reinforcement in the column between the top of the main spiral and the floor level above, it shall be provided by a stub spiral ( short section of spiral ) or by circular column ties. This is necessary to permit placing of the reinforcement in the floor system. Where stub spirals are used, they should be attached to the main spiral for transportation or carefully identified by bar type numbers.

**6.11.3 Piles** — The most common use of spirals is in reinforced concrete piles. They restrain the longitudinal bars during driving of the pile and support the structural loads. Piling spirals are generally furnished formed to the required diameter and with the proper number of turns, but unmounted, that is without rigid spacers to hold the spirals to a designated pitch. The spiral is tied and transported in a compact bundle. On the job it is untied and pulled out over the longitudinal piling bars for the proper specified distance. It is then tied to the longitudinal bars at the required pitch. The diameter varies with each turn. Two types of spiral are fabricated, the circular spiral for round or octagonal piles and the square spiral for square piles. Spirals may be supplied in two or more pieces. The tapered spiral is always furnished separately and the constant shaped spiral may be furnished in more than one piece to suit the length of spiral stock available or the fabricator's equipment. Unless the separate pieces contain the same number of turns, they should be carefully marked to ensure proper placing. At least one and one-half extra turns of spiral should be provided at the ends of each section of spiral and the extra turns from one section lapped into that of the adjoining section.

**6.11.3.1** Spirals are also used in circular caissons, columns of continuous bents for viaducts, columns over arches, and other special cases. When thus used, they are generally mounted on spacers to hold the spiral firmly in place at the desired pitch during placing of the concrete.

**6.12 Edge Beams** — Where the designer shows stirrups in any edge or spandrel beam, these stirrups shall be closed and at least one longitudinal bar shall be located in each corner of the beam section, the size of this bar to be at least equal to the diameter of the stirrup but not less than 12 mm  $\phi$ . These details shall be clearly indicated by the designer. Typical details are shown in Fig. 11 for normal and upturned edge or spandrel beams. For easier placing of the longitudinal bars in the beam, details for two-piece closed stirrups are also shown. For the same reason, the 90° stirrup hook is preferred ( see Fig. 11 ). The designer should show the general arrangement of all such bars and stirrups.

**6.13 Wall Intersections and Corners** — Horizontal wall reinforcement may be required by the designer to resist moment, shear, or merely changes in length due to temperature or shrinkage. In any case, unless the designer



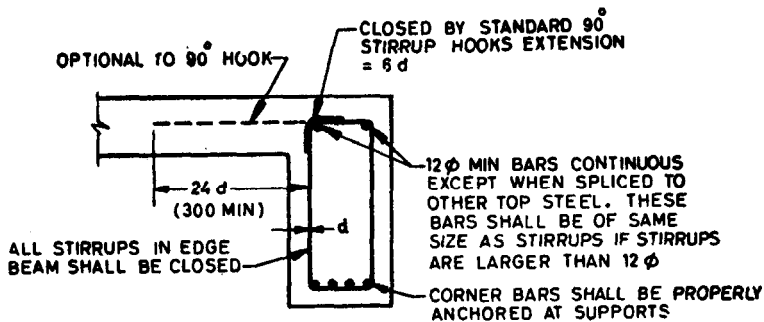

STIRRUPS AS CLOSED TIE

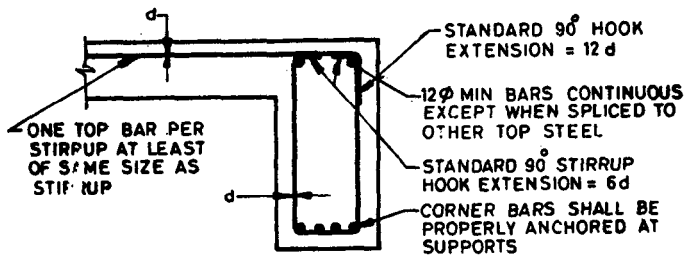

STIRRUPS AND TOP BARS FORM CLOSED TIE

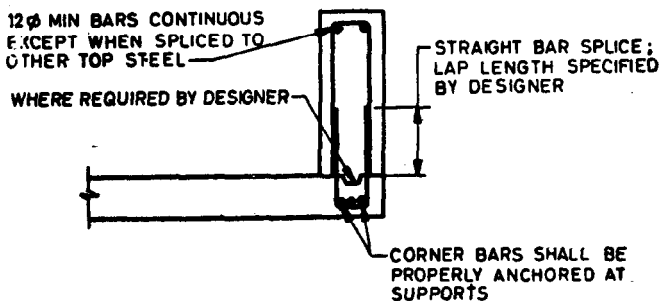

TWO-PIECE STIRRUPS FORM CLOSED TIE

All dimensions in millimetres.

FIG. 11 TYPICAL DETAILS OF REINFORCEMENT IN EDGE AND SPANDREL BEAM

indicates a shrinkage control joint at this point, all the horizontal bars in one or sometimes both faces of a wall should be sufficiently extended past a corner or intersection to be fully developed (see Fig. 12). Nevertheless it is necessary for the designer to indicate which, if any, horizontal reinforcement should be extended for full development at intersections and corners of walls and footings. Typical details are shown in Fig. 12 for resistance against moment inward, outward, or both, with the reinforcement from the appropriate face or faces anchored.

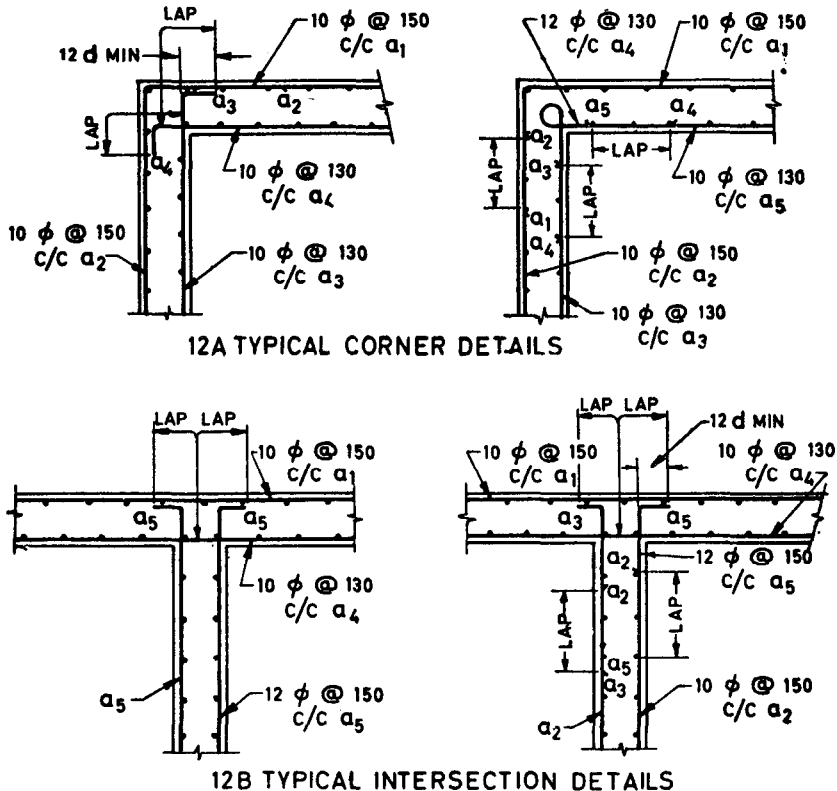

FIG. 12 TYPICAL CORNER AND INTERSECTION DETAILS FOR WALLS

## 7. WELDED WIRE FABRIC

**7.1 General** — Welded wire fabric is either oblong mesh or square mesh and is supplied in either rolls or flat sheets. The details regarding material,

types and designation, dimensions, sizes of sheets or rolls, weight, tolerances, mechanical properties, etc, are covered in IS : 1566-1967\*.

**7.2 Designation** — Welded wire fabric should be designated as recommended in IS : 1566-1967\*, that is either by complete description of the fabric specifying the desired mesh size and diameter of both longitudinal and transverse wires, or by the reference number of the mesh as indicated in Appendix A of IS : 1566-1967\*. While denoting size of sheet or roll of oblong mesh fabric the first dimension shall be length of main wires.

### 7.3 Detailing

**7.3.1** To ensure that correct size of fabric is laid in right direction, small sketches should be inserted on the plan to indicate the direction of span of the fabric. Details at *A* and *B* in Fig. 13 will indicate square and oblong welded wire fabric respectively in plan view of slab.

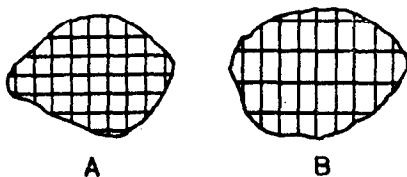

FIG. 13 WELDED WIRE FABRIC IN PLAN VIEW OF SLAB

**7.3.2** The actual position of the welded wire fabric sheet in slab panels may be shown by a diagonal line together with the description of the mesh used. Bottom sheets should be shown with diagonal drawn from bottom left-hand corner to the top right-hand corner. Top sheets should be shown from top left-hand corner to the bottom right-hand corner. A schedule may also be included in the structural drawing indicating the mesh sizes and length and width, and cutting details for welded wire fabric sheets for different slab panels. A typical plan and schedule is given in Fig. 14 and Fig. 15.

### 7.4 LAPS

**7.4.1** The fabric is supplied in long rolls and it is rarely necessary to have a joint of the main wires. The rigidly connected cross members provide mechanical anchorage, and adequate lapping where necessary, may be accomplished with a comparatively short lap when cross wires occur within the lap.

**7.4.2** In structural slabs, laps in regions of maximum stress shall be avoided. Such splices where used for either end or edge laps, shall be made so that the distance between outermost cross wire of each fabric sheet is not less than the spacing of the wire parallel to the lap plus 50 mm ( see Fig. 16A ).

\*Specification for hard-drawn steel wire fabric for concrete reinforcement.

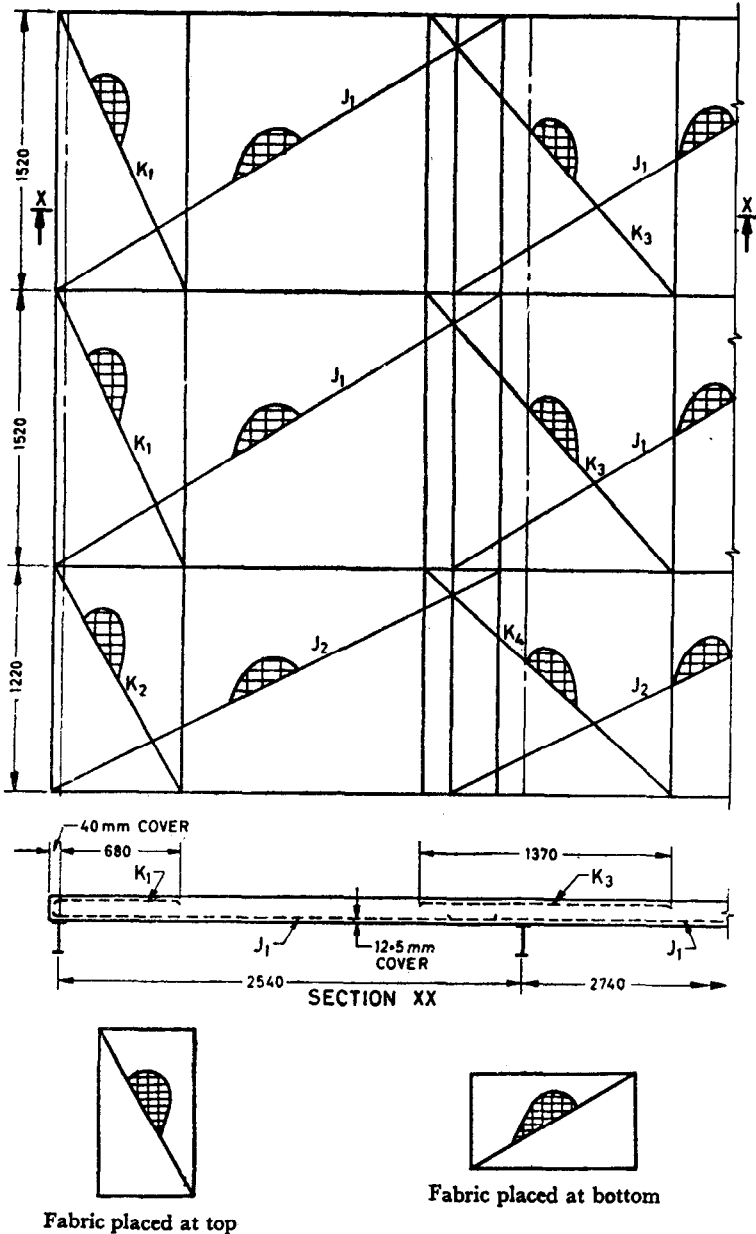

All dimensions in millimetres.

FIG. 14 PLAN SHOWING TYPICAL DETAILS OF WELDED WIRE FABRIC AT TOP AND BOTTOM OF SLAB

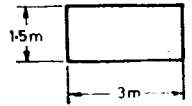
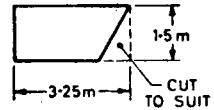
Mark and Location of Member		Drawing Reference	No. of Members/Panels	Fabric Designation No. as per IS:	Fabric Reference	No. in Each Member/ Panel	Total No.	Width	Length	Cutting	Remarks
(1)		(2)	(3)	(4)	(5)	(6)	(7)	(8)	(9)	(10)	(11)
Mark	Location	Drg No. Stc.....	2	42	J <sub>1</sub>	4	8	1.5 m	3 m		Hard-drawn steel wire fabric conforming to IS : 1566-1966
S <sub>b</sub> 7, S <sub>b</sub> 8	Floor 2										
S <sub>b</sub> 10	Floor 2	Drg No. Stc.....	1	42	J <sub>s</sub>	1	1	1.5 m	3.25 m		

**FIG. 15 TYPICAL SCHEDULE FOR SLAB USING WELDED WIRE FABRIC AS REINFORCEMENT**

**7.4.3** In other cases for end laps, welded wire fabric shall be lapped not less than one mesh plus 50 mm, that is, the length of the lap shall be 50 mm greater than the spacing of wires parallel to the lap (see Fig. 16B). For edge laps, a lap of 50 mm is sufficient (see Fig. 16C).

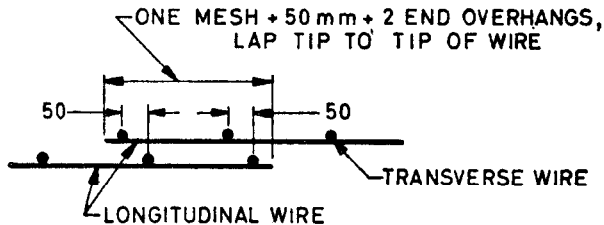

### 16A MORE THAN HALF STRESS END AND EDGE LAPS

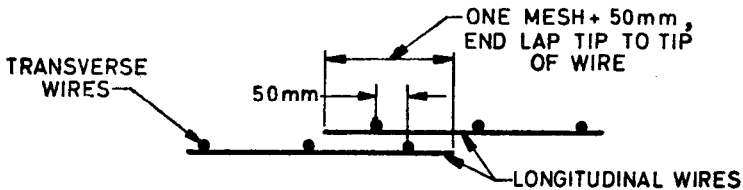

### 16 B HALF STRESS END LAP

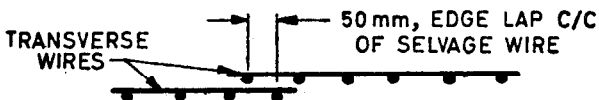

### 16C HALF STRESS EDGE LAP

FIG. 16 TYPICAL DETAILS FOR LAPS IN WELDED WIRE FABRIC

**7.4.4** These requirements for lapping should be covered by suitable clauses in the general specifications. But whether specified by wording or shown on the plans, certain distinctions should be made between edge laps and "end laps".

**7.4.5** The width of an edge lap shall be indicated as the centre to centre distance between the outside or selvage longitudinal wires of the overlapping sheets as illustrated in Fig. 16.

**7.4.6** The length of an end lap shall be indicated as the tip-to-tip distance between the ends of the longitudinal wires of the overlapping sheets as illustrated in Fig. 16.

# BUREAU OF INDIAN STANDARDS

## Headquarters :

Manak Bhavan, 9 Bahadur Shah Zafar Marg, NEW DELHI 110002

Telephones : 331 01 31

331 13 75

Telegrams : Manaksanstha

(Common to all Offices)

## Regional Offices :

		<i>Telephone</i>
Central	: Manak Bhavan, 9, Bahadur Shah Zafar Marg, NEW DELHI 110002	{ 331 01 31 331 13 75
* Eastern	: 1/14 C.I.T. Scheme VII M, V.I.P. Road, Maniktola, CALCUTTA 700054	37 86 62
Northern	: SCO 445-446, Sector 35-C, CHANDIGARH 160036	2 18 43
Southern	: C.I.T. Campus, IV Cross Road, MADRAS 600113	41 29 16
† Western	: Manakalaya, E9 MIDC, Marol, Andheri (East), BOMBAY 400093	6 32 92 95

## Branch Offices :

'Pushpak',	Nurmohamed Shaikh Marg, Khanpur, AHMADABAD 380001	2 63 48
‡ Peenya Industrial Area,	1st Stage, Bangalore-Tumkur Road, BANGALORE 560058	39 49 55
Gangotri Complex,	5th Floor, Bhadbhada Road, T.T. Nagar, BHOPAL 462003	55 40 21
Plot No. 82/83,	Lewis Road, BHUBANESHWAR 751002	5 36 27
Kalai Kathir Building,	6/48-A Avanasai Road, COIMBATORE 641037	2 67 05
Quality Marking Centre,	N.H. IV, N.I.T., FARIDABAD 121001	—
Savitri Complex,	116 G. T. Road, GHAZIABAD 201001	8-71 19 96
53/5 Ward No. 29,	R.G. Barua Road, 5th By-lane, GUWAHATI 781003	3 31 77
5-8-56C L. N. Gupta Marg,	( Nampally Station Road ) HYDERABAD 500001	23 10 83
R14 Yudhister Marg,	C Scheme, JAIPUR 302005	6 34 71
117/418 B Sarvodaya Nagar,	KANPUR 208005	21 68 76
Plot No. A-9, House No. 561/63,	Sindhu Nagar, Kanpur Road, LUCKNOW 226005	5 55 07
Patliputra Industrial Estate,	PATNA 800013	6 23 05
District Industries Centre Complex,	Bagh-e-Ali Maidan, SRINAGAR 190011	—
T. C. No. 14/1421, University P. O.,	Palayam, THIRUVANANTHAPURAM 695034	6 21 04

## Inspection Offices (With Sale Point) :

Pushpanjali, First Floor,	205-A West High Court Road.	52 51 71
Shankar Nagar Square,	NAGPUR 440010	
Institution of Engineers (India) Building,	1332 Shivaji Nagar.	5 24 35
	PUNE 411005	

\*Sales Office Calcutta is at 5 Chowringhee Approach,  
P. O. Princep Street, CALCUTTA

† Sales Office is at Novelty Chambers, Grant Road, BOMBAY

‡ Sales Office is at Unity Building, Narasimharaja Square,  
BANGALORE